

THIS DRAWING IS UNPUBLISHED. RELEASED FOR PUBLICATION ,19 .  
 © COPYRIGHT 19 BY AMP INCORPORATED. ALL INTERNATIONAL RIGHTS RESERVED.

MOD	LOC	DIST	P	F	ZONE	LTR	DESCRIPTION	DATE	APPD
4	BD	35				H	REDRAWN	6-26-91	-
						J	OBS -2 PER EC 0020-0394-93	11/17/94	RK

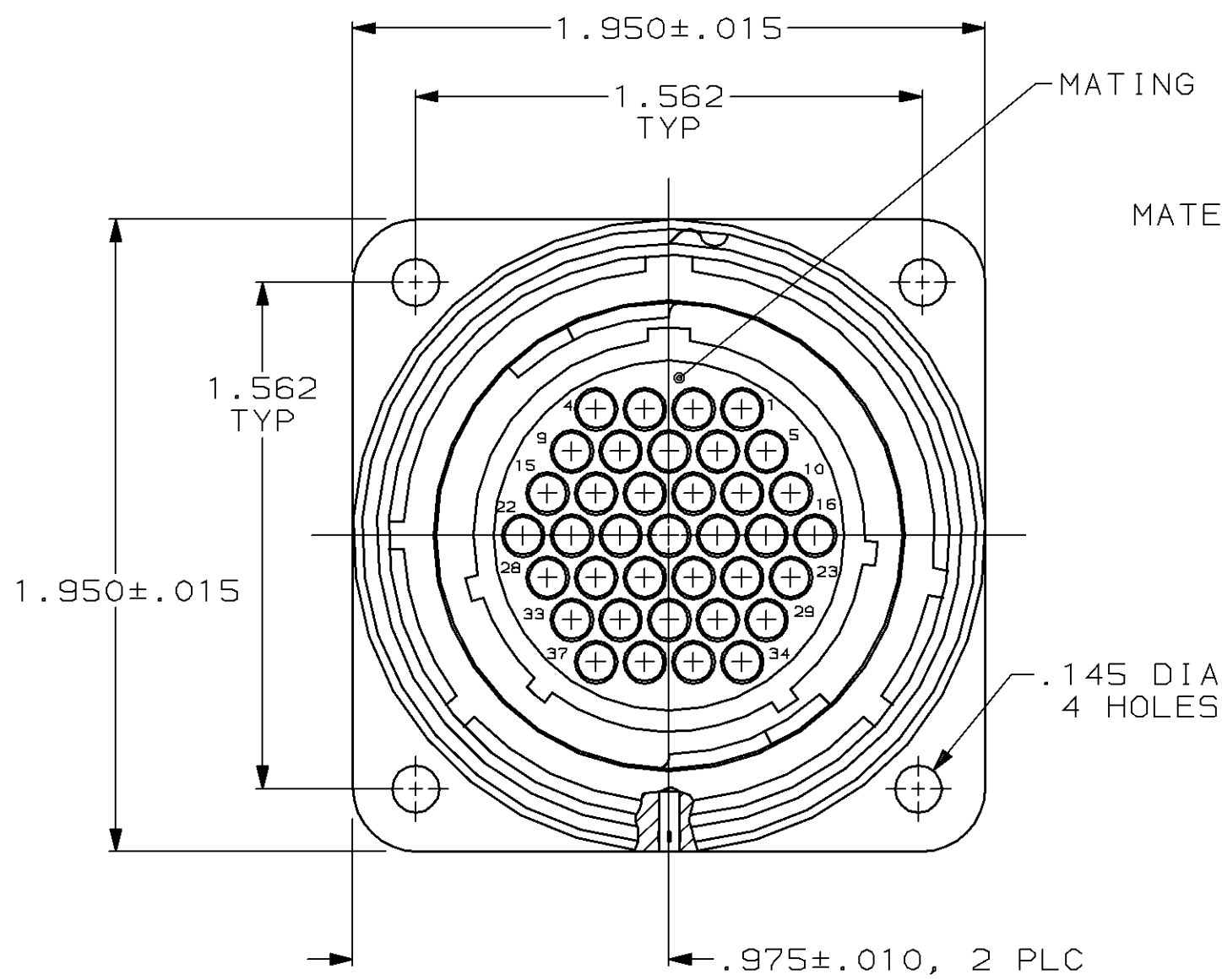

METAL SHELL RECEPTACLE  
 MATERIAL: ZINC ALLOY  
 FINISH: NICKEL PLATED  
 PER QQ-N-290

GROOVED PIN, 2 PLC  
 MATERIAL: STEEL ALLOY  
 FINISH: NICKEL PLATED  
 PER QQ-N-290

PERIPHERAL SEAL  
 SEE TABLE

1.900 MAX

.125 MAX  
 PANEL THK

.875±.010

.125±.010

1.260 MAX

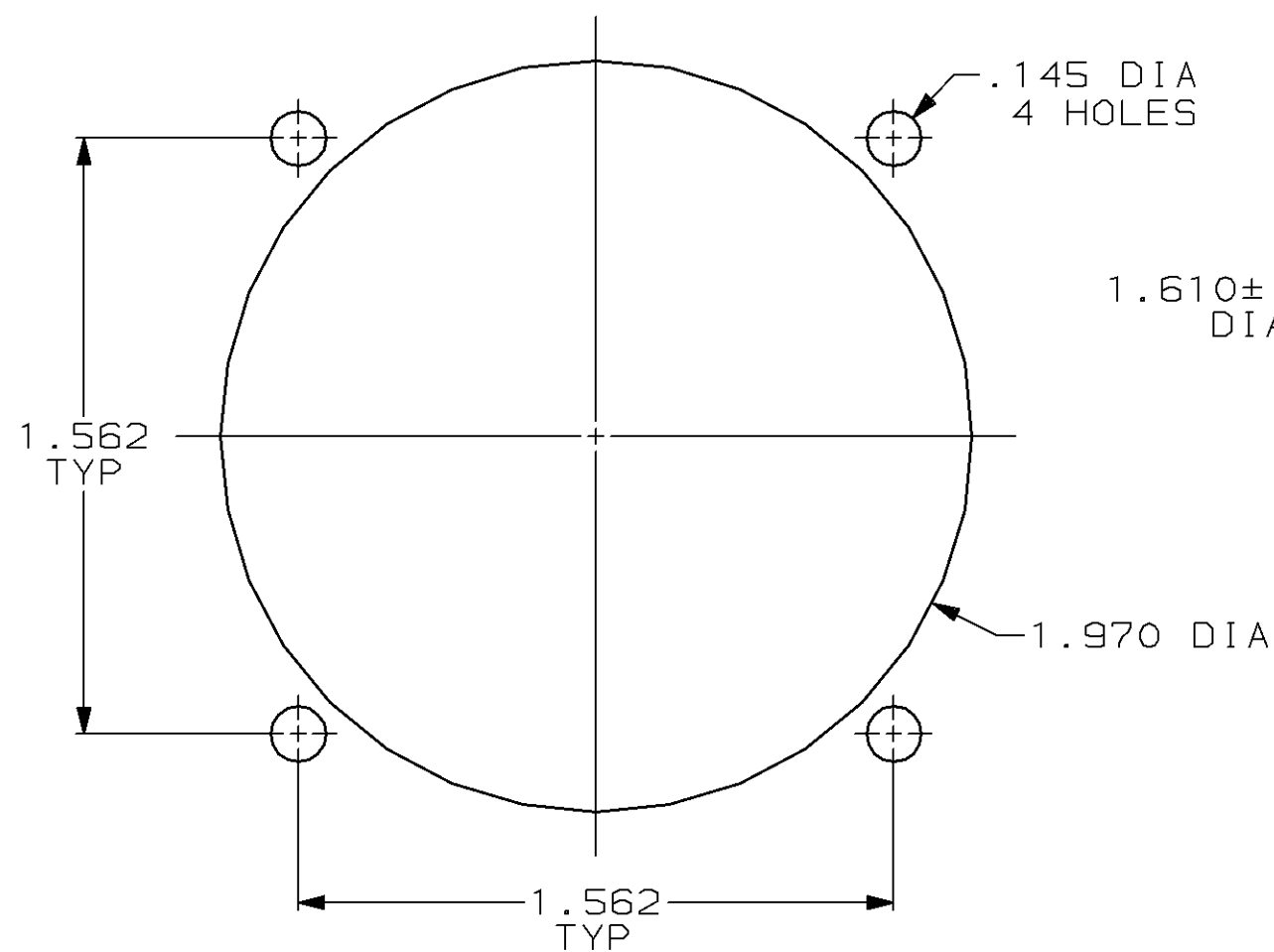

1.610±.010  
 DIA

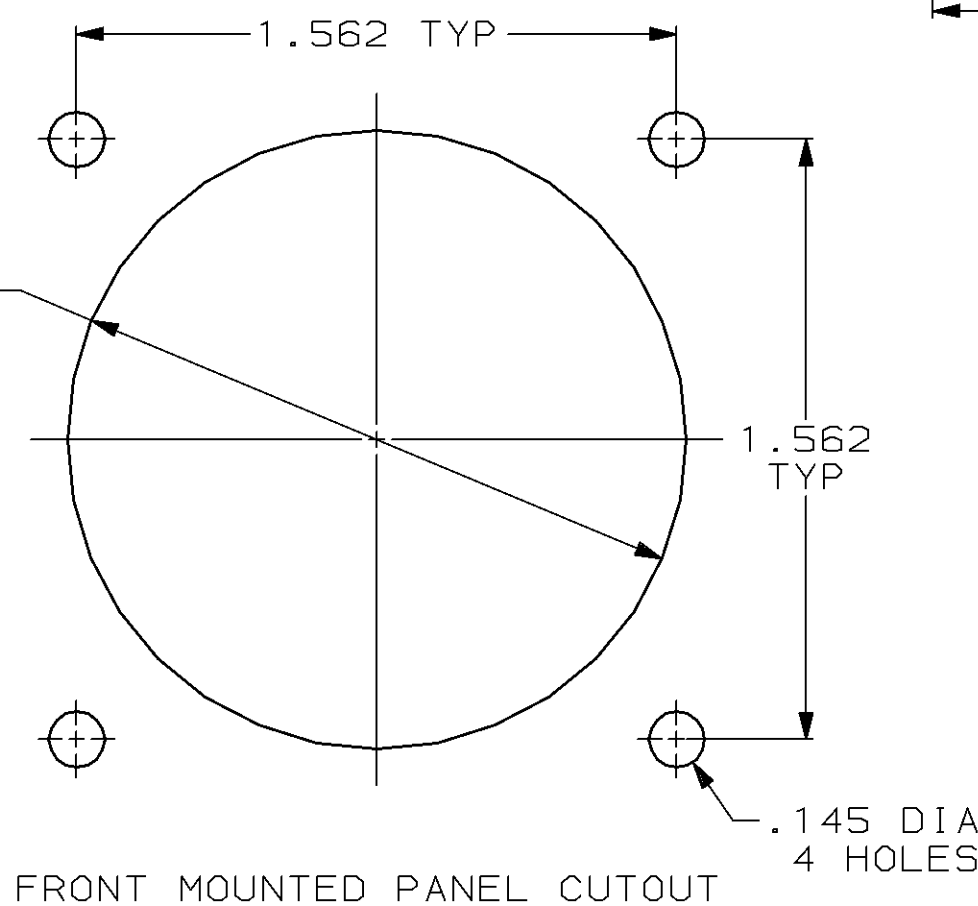

FRONT MOUNTED PANEL CUTOUT

REAR MOUNTED PANEL CUTOUT

OBSOLETE	YES	208473-2
	NO	208473-1
PERIPHERAL SEAL		PART NUMBER

- 208473-1 MATES WITH AMP PLUG 208472-1 OR -3. 208473-2 MATES WITH 208472-1 ONLY.
- AMP PART NUMBER AND DATE CODE TO BE LOCATED ON EDGE OF FLANGE.

DO NOT SCALE PRINT. UNLESS SPECIFIED DIMENSIONS IN INCHES TOLERANCES ON :  
 2 PLC DEC ± -  
 3 PLC DEC ± .005  
 ANGLES ± -  
 MATERIAL SEE CALLOUT  
 FINISH SEE CALLOUT

DR 6-26-91 R.LEE BG  
 CHK 4-15-92 W.G.LENKER  
 APPD 4-15-92 K.BEAVER  
 APPD 4-15-92 C.ROHDE  
 PRODUCT SPEC 108-10040  
 APPLICATION SPEC -  
 WEIGHT -

**AMP** AMP Incorporated  
 Harrisburg, PA 17105-3608

NAME  
 RECEPTACLE ASSEMBLY, REV SEX,  
 SERIES 1, 28-37, CMC

SIZE	CAGE CODE	DRAWING NO
Ⓢ	00779	208473
SCALE	2:1	SHEET 1 OF 1